

DETACHABLE CONTAINER GARBAGE TRUCK



Main Parameters

Items		FLM5180ZXXDF6NG	FLM5250ZXXDF6NG
GVW	kg	18000	25000
Wheelbase	mm	4500	4350+1350
Payload Weight	kg	9455	12715
Upper Weight	kg	2150	3155
Upper Transportation Dimensions	mm	4810×2500×2470	6050×2530×2500
Selectable Of Hook loader		Palfinger/Wole/Multilift	Palfinger/Wole/Multilift
Max Lifting	kg	14000	20000
Max Self-discharging Angle		50°	50°
Loading Time	s	≤60	≤60
Discharging Time	s	≤72	≤72
Discharging Cycle Time	s	≤110	≤110
Hydraulic System Pressure	MPa	30	30
Power Type		LNG	LNG

Technical Specification

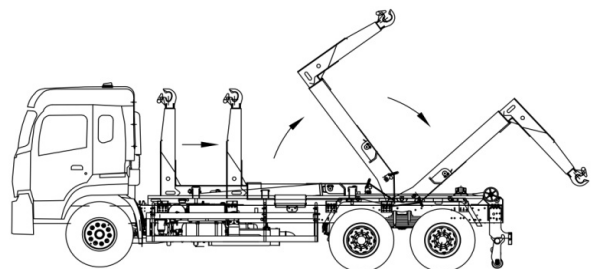
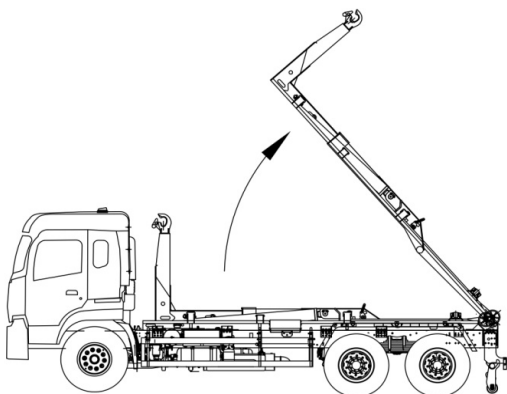

Base Specification

Chassis:

- It is reformed from chassis, with strong horsepower, economy and environmental protection.

Hook System:

- The hook arm system adopts the power take-off system, which adopts the power take-off output. Compared with the electromagnetic clutch power take-off mode of similar vehicles, it is more convenient for installation and maintenance, and has better reliability. Moreover, the push-pull flexible shaft is used to control the power take-off output and close, which truly realizes the separation of driving and operation, and improves the service life of the power take-off system.
- The hook arm device adopts the linkage structure, which integrates the switching of operation mode, the limit of lock box and turnover frame, simplifies the operation control system, protects the lifting oil cylinder, reduces the failure rate of the hook arm, and extends the service life of the hook arm.
- Hook arm is made of high-quality steel plate with high wear resistance and durability; safety lifting hook is made of high-strength wear-resistant steel,

Control system:

- All operations can be completed in the cab, which is simple and convenient to operate and reduces the labor intensity of the operator.

Safety:

- The connection between chassis and hook arm system is made of high-quality steel plate, safe, stable and reliable.
- The safety lock of the box is safe and reliable. When the vehicle is running, the box will not shake.

Other advantage:

- It integrates loading, transportation and self-unloading, without auxiliary equipment, and is easy to operate.
- One vehicle with multiple boxes, circulating transportation, improving vehicle use efficiency and reducing cost.

Optional device:

- The power unit with fast electric control plug is equipped.
- Aluminum alloy side guard rail is installed.
- Optional sewage device.
- FLM5180ZXXDF6NG:
 - 1.Optional cleaning device.
 - 2.Wole LBH1442C/Palfinger T15S (vertical valve) / Multilift XP14S (Three choose one).
- FLM5250ZXXDF6NG:
 - 1.Optional bridge support.
 - 2.Choose Wole LBH2055/Palfinger T20S) (Two choose one).
 - 3.Multilift XP20S.